

**Fixture housing:** Galvanized steel previously stove-enamelled with UV-stabilised white polyester resin; rounded edges to prevent cutting; polycarbonate end caps.

**Electric gear:** 230V/50Hz. Hard wire, cross section 0.50 sqmm, and high-temperature resistant (up to 90°C) PVC-HT sheath, in accordance with CEI 20-20 standards. 2P+T terminal block (maximum allowed lead cross section 2.5 sqmm.).

**Standard supply:** Nylon fastening pawl.

6401 Rapid system T8 - with knife switch							
		CNR		CEL		CNR-E	
wattage	colour	weight	code	weight	code	weight	code
FL 1x18	white	1.10	238040-00	0.90	238040-08		
FL 1x30	white	1.30	238041-00	1.10	238041-08		
FL 1x36	white	1.50	238042-00	1.40	237531-00	2.50	237551-00
FL 1x58	white	2.00	238043-00	1.80	237532-00	2.80	237552-00

Acc. 4605 for direct ceiling mounting. **Note: 6401EL: order the special version of acc 6405.**

6501 Rapid system T8 - with knife switch							
		CNR		CEL		CNR-E	
wattage	colour	weight	code	weight	code	weight	code
FL 2x18	white	1.15	238045-00	0.95	238045-08		
FL 2x36	white	2.05	238046-00	1.95	237536-00	3.00	238046-07
FL 2x58	white	2.95	238047-00	2.75	237537-00	4.00	237557-00

Acc. 4605 for direct ceiling mounting. **Note: 6401EL: order the special version of acc 6405.**

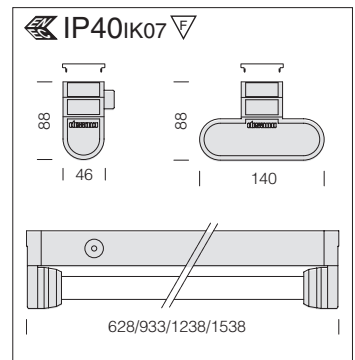
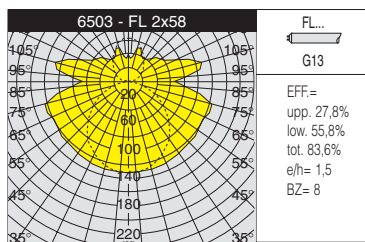
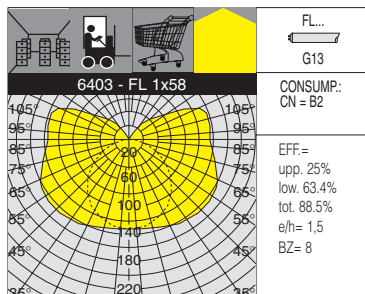

**Fixture housing:** Galvanized steel previously stove-enamelled with UV-stabilised white polyester resin; rounded edges to prevent cutting; polycarbonate end caps.

**Electric gear:** 230V/60Hz power supply with ΔT 45 electronic ballast. Hard wire, cross section 0.50 sqmm, and high-temperature resistant (up to 90°C) PVC-HT sheath, in accordance with CEI 20-20 standards. 2P+T terminal block (maximum allowed lead cross section 2.5 sqmm.).

**Standard supply:** Nylon fastening pawl.

Supplied with power terminal block and upper cover acc. 6405 for direct ceiling or wall mounting. For centralised power factor correction installations.

6403 Rapid system T8 - with upper cover				
		CN		
wattage	colour	weight	code	
FL 1x18	white	1.20	238120-00	
FL 1x30	white	1.50	238121-00	
FL 1x36	white	1.70	238122-00	
FL 1x58	white	2.10	238123-00	

6503 Rapid system T8 - with upper cover				
		CN		
wattage	colour	weight	code	
FL 2x18	white	1.25	238124-00	
FL 2x36	white	2.15	238125-00	
FL 2x58	white	3.05	238126-00	

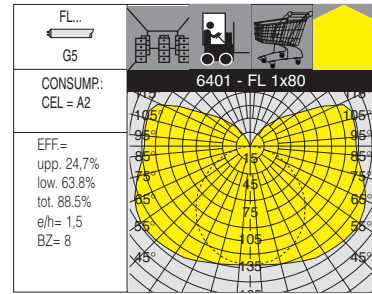
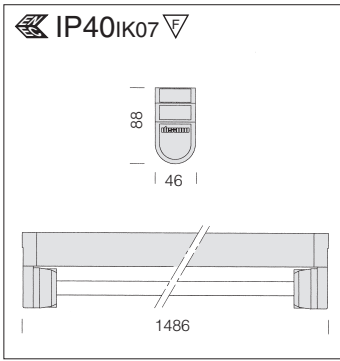

**Fixture housing:** Galvanized steel previously stove-enamelled with UV-stabilised white polyester resin; rounded edges to prevent cutting; polycarbonate end caps.

**Electric gear:** 230-240V/50-60Hz. Hard wire, cross section 0.50 sqmm, and high-temperature resistant (up to 90°C) PVC-HT sheath, in accordance with CEI 20-20 standards. 2P+T terminal block (maximum allowed lead cross section 2.5 sqmm.).

**Standard supply:** Nylon fastening pawl.

6401 Rapid system T5 - with knife switch			
		CEL	
wattage	colour	weight	code
FL 1x80	white	2.90	238050-00
FL 1x49	white	2.90	238054-00

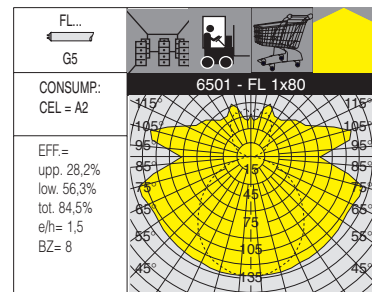
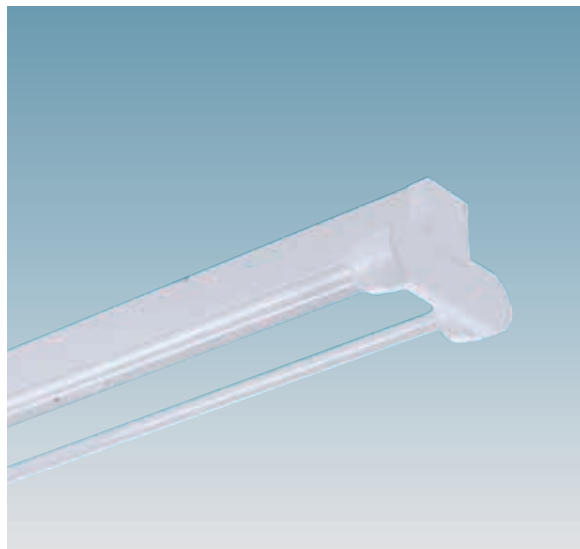
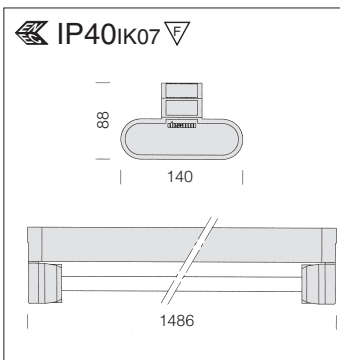

**Fixture housing:** Galvanized steel previously stove-enamelled with UV-stabilised white polyester resin; rounded edges to prevent cutting; polycarbonate end caps.

**Electric gear:** 230-240V/50-60Hz power supply with ΔT 55 electronic ballast. Hard wire, cross section 0.50 sqmm, and high-temperature resistant (up to 90°C) PVC-HT sheath, in accordance with CEI 20-20 standards. 2P+T terminal block (maximum allowed lead cross section 2.5 sqmm.).

**Standard supply:** Nylon fastening pawl.

6501 Rapid system T5 - with knife switch			
		CEL	
wattage	colour	weight	code
FL 2x80	white	2.90	238051-00
FL 2x49	white	2.90	238055-00

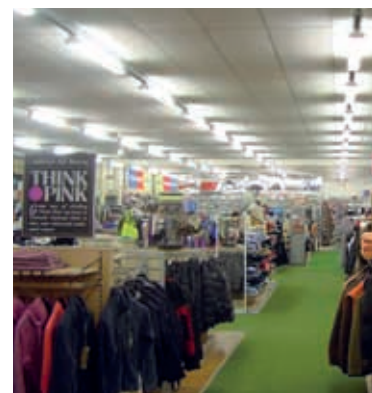

acc. 79 knife switch	
	985005-00
For quick connection to the power line and for automatic power line cutoff during maintenance. To be used with acc 6030.	

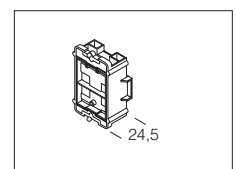
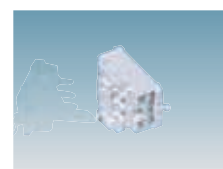

● = application examples

<b>acc. 6412 one/two-lamp reflector</b>	
<b>1x80</b>	237744-00
Diffusing. Polished high gloss aluminium 99.85, anodized 2μ.	

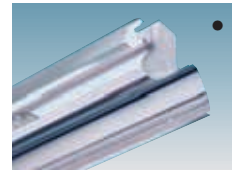
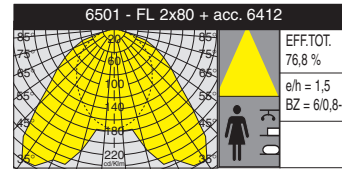
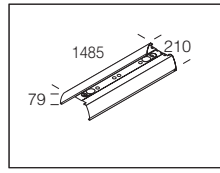
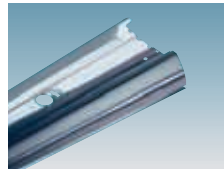

<b>acc. 6413 single narrow beam refl.</b>	
<b>1x80</b>	237736-00
Polished high-gloss aluminium 99.85, anodised 2μ.	
<b>Applications:</b> warehouses with high narrow corridors.	

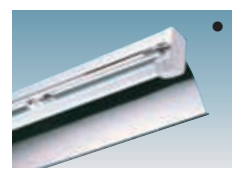
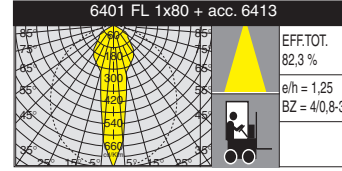
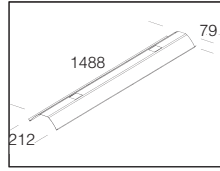
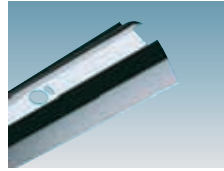

<b>acc. 6414 concave reflector</b>	
<b>2x80</b>	237739-00
Polished high-gloss aluminium 99.85, anodised 2μ.	
<b>Applications:</b> warehouses with high narrow corridors.	

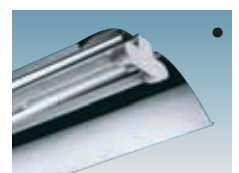
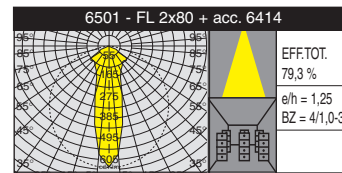
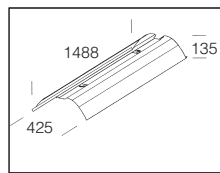
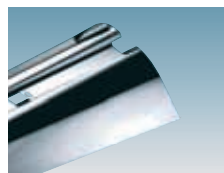

<b>acc. 6416 one/two-lamp diffuser</b>	
<b>1/2x18</b>	237741-00
<b>1/2x36</b>	237742-00
<b>1/2x58</b>	237743-00
<b>1/2x80</b>	237747-00
Made of steel, pre-painted white with polyester resin.	

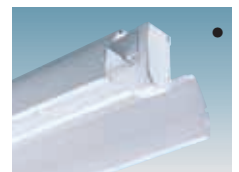
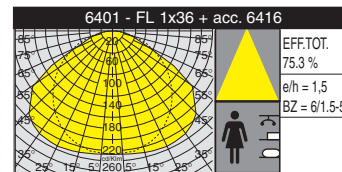
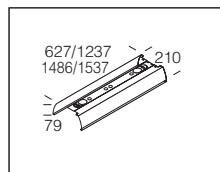
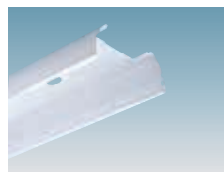

<b>acc. 6440 one-lamp corner refl.</b>	
<b>1x18</b>	237715-00
<b>1x36</b>	237716-00
<b>1x58</b>	237717-00
Made of steel, pre-painted white with polyester resin.	
<b>Applications:</b> working benches.	

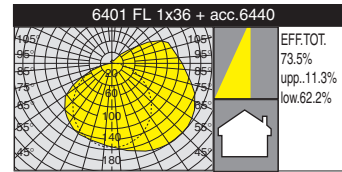
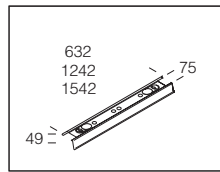

<b>acc. 6417 dir/ind. light reflector</b>	
<b>1/2x36</b>	237745-00
<b>1/2x58</b>	237746-00
Made of steel. The fixture provides direct and indirect light with upper slots for indirect output.	

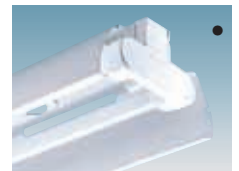
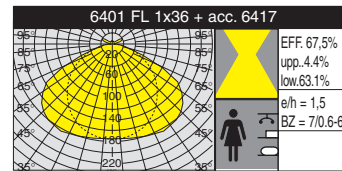
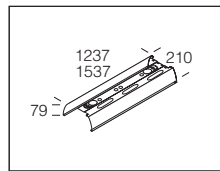
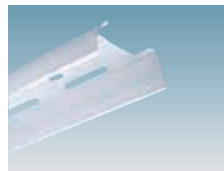

<b>acc. 6413 single narrow beam refl.</b>	
<b>1x36</b>	237734-00
<b>1x58</b>	237735-00
Polished high-gloss aluminium 99.85, anodised 2μ.	
<b>Applications:</b> warehouses with high narrow corridors.	

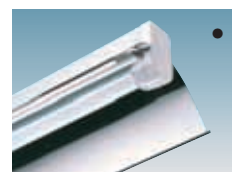
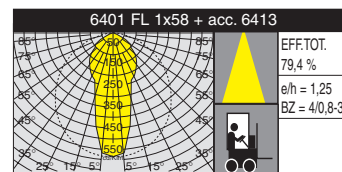
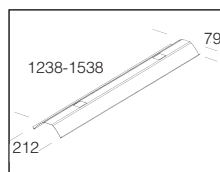
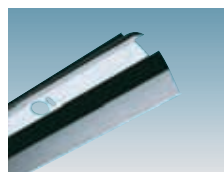

<b>acc. 6424 one/two-lamp louvre</b>	
white	237759-00
metal.	237760-00
Made of polycarbonate. For better light control and to reduce glare. For T8.	

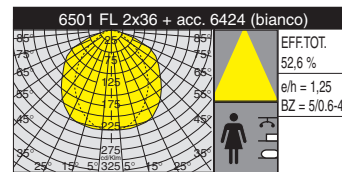
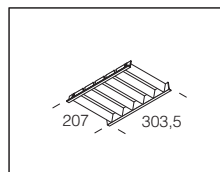
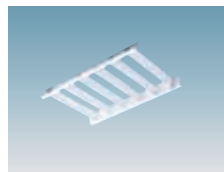

<b>acc. 6411 reflector asymmetric</b>	
<b>1x36</b>	237620-00
<b>1x58</b>	237621-00
<b>1x49/80</b>	237622-00

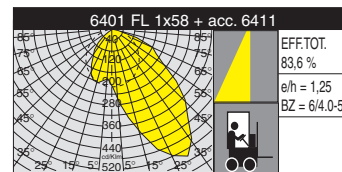
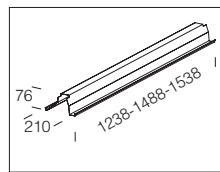
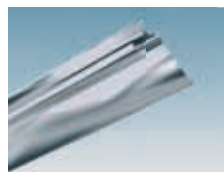

<b>acc. 6405 upper cover</b>	
<b>18</b>	237603-00
<b>30</b>	237602-00
<b>36</b>	237604-00
<b>58</b>	237605-00
<b>1/2x80</b>	237612-00
White steel. For ceiling mounting.	

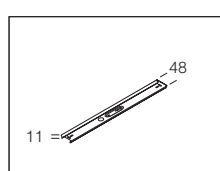

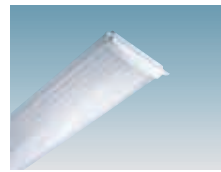
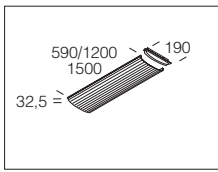
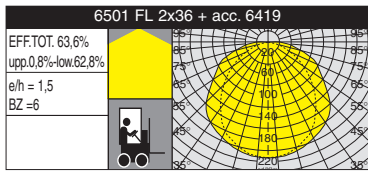

<b>acc. 6419 one/two-lamp diffuser</b>	
<b>1/2x18</b>	237750-00
<b>1/2x36</b>	237751-00
<b>1/2x58</b>	237752-00

Plexiglass, fluted inside and smooth outside, to be applied on reflector acc 6416/6417.

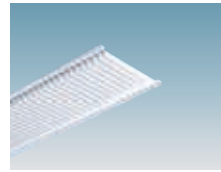
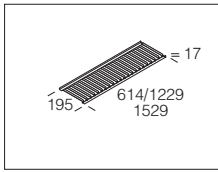
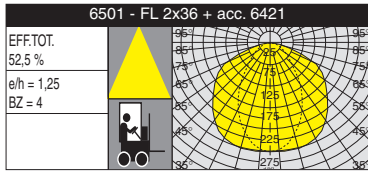

<b>acc. 6421 one/two-lamp louvre</b>	
<b>1/2x18</b>	237753-00
<b>1/2x36</b>	237754-00
<b>1/2x58</b>	237755-00

Made of sheet steel, painted white. To be applied to art.6416/6417.

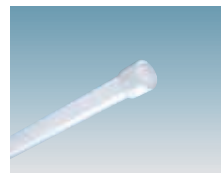
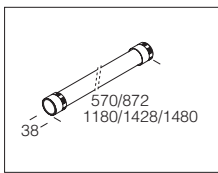
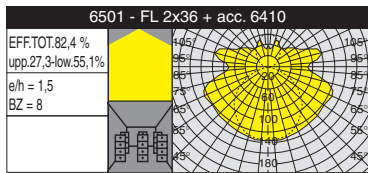

<b>acc. 6410 protection tube</b>	
<b>1/2x18</b>	237606-00
<b>1x30</b>	237601-00
<b>1/2x36</b>	237607-00
<b>1/2x58</b>	237608-00
<b>1/2x80</b>	237615-00

V2 polycarbonate. Scored inside; smooth, dustproof outside.

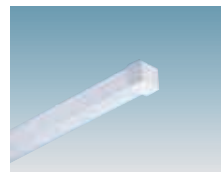
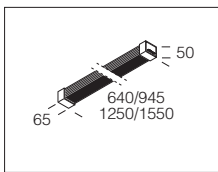
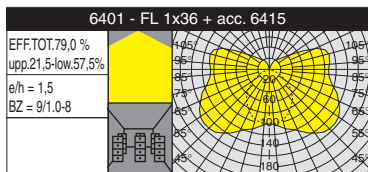

<b>acc. 6415 one-lamp diffuser</b>	
<b>1x18</b>	237609-00
<b>1x30</b>	237600-00
<b>1x36</b>	237610-00
<b>1x58</b>	237611-00

Plexiglass, fluted inside.

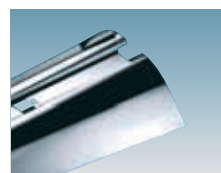
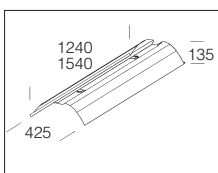
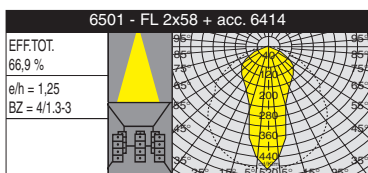

<b>acc. 6414 concave reflector</b>	
<b>2x36</b>	237737-00
<b>2x58</b>	237738-00

Polished high-gloss aluminium 99,85, anodised 2µ.

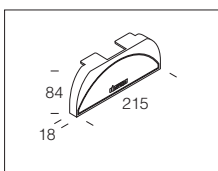

<b>acc. 6423 end cap</b>	
white	237757-00

Made of ABS. To be used as end cap for stand-alone or end reflectors of a continuous line.  
**2 per pack.**

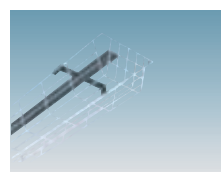
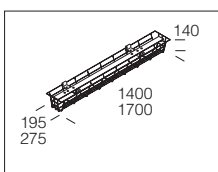

<b>acc. 975 impact protection guard</b>	
<b>1x36</b>	165564-00
<b>1x58</b>	165565-00
<b>2x36</b>	165566-00
<b>2x58</b>	165567-00

White plastic-coated steel rod. To be installed directly on the ceiling.

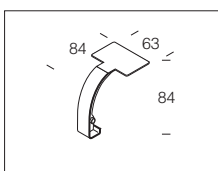

<b>acc. 6422 alignment joint</b>	
white	237756-00

Made of ABS. To align accessories 6416/6417/6418 installed in a continuous line. **2 per pack.**

● = application examples

